

# INSTRUCTIONS FOR USE

en

## Thermia Pro mounted Thermia Pro stand-alone





# **IMPORTANT**

**READ CAREFULLY BEFORE USE**

**KEEP THESE INSTRUCTIONS FOR FUTURE  
CONSULTATION**

© Möller Medical GmbH  
All rights reserved.

No part of this documentation may be reproduced or translated in any way whatsoever without prior written approval from Möller Medical GmbH. The status of the information, specifications and figures in these instructions for use is indicated by the version number on the last page. Möller Medical GmbH reserves the right to make changes to the technology, functions, specifications, design and information at any time and without prior notification.

## Contents

<b>Contents</b> .....	<b>4</b>
<b>1 General safety information</b> .....	<b>6</b>
1.1 Explanation of the safety symbols used .....	6
1.1.1 Symbols in the instructions for use .....	6
1.1.2 Symbols on the device .....	6
1.1.3 Additional symbols on the retail packaging .....	7
1.2 Explanation of the format conventions used .....	8
1.3 Manufacturer's responsibility .....	8
1.4 Operator's duty of care .....	9
1.5 Warning notices .....	10
1.6 Non-device-related additional equipment .....	10
1.7 Declaration on DEHP .....	11
1.8 Precautionary measures .....	11
1.9 Target group (users) .....	11
<b>2 Intended use</b> .....	<b>12</b>
2.1 Contraindications .....	12
2.2 Complications .....	12
2.3 Essential performance features .....	12
2.4 Combination with other products .....	12
<b>3 Product description</b> .....	<b>13</b>
3.1 Thermia Pro Console .....	13
3.2 Thermia Pro Heating Trays mounted .....	14
3.3 Thermia Pro Heating Trays stand-alone .....	14
<b>4 Setup and commissioning</b> .....	<b>15</b>
4.1 Transport and storage information .....	15
4.2 Unpacking the devices and checking the delivered items .....	15
4.3 Suitable operating environment .....	16
4.4 Use with defibrillation and RF surgical devices .....	16
<b>5 Setup</b> .....	<b>17</b>
5.1 Setting up the Thermia Pro mounted .....	17
5.2 Setting up the Thermia Pro stand-alone .....	19
<b>6 Commissioning</b> .....	<b>20</b>
<b>7 Cleaning and care</b> .....	<b>23</b>
<b>8 Help in the event of a fault</b> .....	<b>24</b>
<b>9 Service</b> .....	<b>25</b>
9.1 Software update .....	26
9.1.1 "First aid" .....	27
<b>10 Disposal</b> .....	<b>28</b>
<b>11 Annex</b> .....	<b>29</b>
11.1 Technical data .....	29
11.2 General data .....	30

**Contents**

**12 Electromagnetic compatibility ..... 31**

    12.1 Electromagnetic emissions .....31

    12.2 Electromagnetic immunity.....32

    12.3 Recommended separation distances.....34

**13 Accessories..... 35**

# 1 General safety information

## 1.1 Explanation of the safety symbols used

Important information is indicated visually in these instructions for use. This information is a prerequisite for preventing hazards to patients and operating personnel, as well as for avoiding damages or malfunctioning of the device.

### 1.1.1 Symbols in the instructions for use



Caution



Information or help



Non-ionising electromagnetic radiation

### 1.1.2 Symbols on the device



Article number



Medical device



Unique identifier of a medical device



Serial number (the first 4 digits indicate the year and month of manufacture in YYMM format)



Refer to instructions for use



Manufacturer

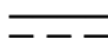







Direct current





Return and disposal as per the WEEE Directive

## General safety information

	Protection class II
	Standby switch
	Device switched on (Standby Off)
	Device switched off (Standby On)
	USB socket
	Input connection for external power supply
	Heat emission, general (Connection for Heating Tray)

### 1.1.3 Additional symbols on the retail packaging

	Consult instructions for use
	Date of manufacture (YYYY-MM-DD)
	Packaging unit
	Do not use if package is damaged
	Store in a dry place
	Air humidity, limitation
	Storage temperature limitation
	Store away from sunlight

## General safety information



Contains or presence of phthalates



Caution



Stacking limit, do not store more than 3 packs high



Attention: Under US Federal law, this device may be only sold to a physician or ordered by a physician.

Further information about the symbols used can be found on our website:

[www.moeller-medical.com/glossary-symbols](http://www.moeller-medical.com/glossary-symbols)

### 1.2 Explanation of the format conventions used

In these instructions for use, different fonts are used to improve orientation.

Font	Use
<b>Bold</b>	Buttons in instructions.
<i>Italics</i>	Device options, buttons and references to chapter and sections in the running text.

*Table 1:  
Format conventions used*

### 1.3 Manufacturer's responsibility

The manufacturer may only be regarded as responsible for the safety, reliability and suitability for use of the devices if:



- Assembly, upgrades, recalibrations, modifications or repairs are performed only by individuals authorised by the manufacturer.
- The electrical installation in the room in question complies with the applicable requirements and regulations (e.g. VDE 0100, VDE 0107 or IEC specifications).
- The devices are used in accordance with the instructions for use and the country-specific regulations and national deviations are observed.
- The conditions stated in the technical data are observed.

Any type of use other than that described in these instructions for use is not permitted and will lead to the exclusion of liability and the loss of warranty.

The manufacturer undertakes to accept old devices as per the German Electrical and Electronic Devices Act (ElektroG).



## General safety information

### 1.4 Operator's duty of care

The operator is responsible for the proper operation of the medical devices. In line with the German Medical Device Operator Ordinance (MPBetreibV), the user must perform a wide range of duties and also assume responsibility when handling medical devices within the framework of his activities. Only qualified personnel may operate the Thermia Pro.

All handling of the Thermia Pro requires precise knowledge and compliance with these instructions for use. The devices may only be operated by persons with the necessary training or knowledge and experience.



The devices are subject to special precautionary measures with respect to electromagnetic compatibility (EMC) and must be installed and operated in accordance with the EMC guidelines.

If one of the devices no longer works properly due to a malfunction, the device must not be used any further and must be inspected by the technical service.

Performance and safety may be compromised if Original Equipment Manufacturer device parts are not used.

All work that requires tools must be performed by the manufacturer's technical service or parties authorised by the latter.

The user must decide whether the patient's body temperature is to be monitored and at what intervals in order to avoid medical risks for example (hypothermia, hyperthermia, etc.).



All serious incidents that occur in connection with the device are to be reported to the manufacturer and the competent authorities of the member state in which the user and/or patient is based.

## General safety information

### 1.5 Warning notices



- The devices must not be modified.
- No liquids must be allowed to penetrate the voltage-carrying parts of the devices.
- When cleaning, ensure that no cleaning agent runs into the connector sockets.
- Disconnect the power cable before cleaning.
- Replace connecting cables of all kinds even if they are only slightly damaged; make sure not to roll over cables.
- Keep the cables away from heat sources. This prevents the insulation from melting, which could cause a fire or an electric shock.
- Do not use force to push plugs into sockets.
- Tighten the plug connections with the maximum manual force available to you. Do not use tools.
- When removing plugs, do not pull on the cables. To remove, release the plug lock if necessary.
- Do not expose the devices to intense heat or fire.
- Do not subject the devices to hard impact.
- If heat, fumes or smoke appear, disconnect the devices from the mains immediately.

### 1.6 Non-device-related additional equipment

Additional equipment that does not belong to the devices' scope of supply and that is connected to the devices' analogue and digital interfaces must be shown to satisfy the relevant EN specifications (e.g. EN 60601 for electromedical devices). Any operator connecting the additional devices is responsible for configuring the system and for ensuring that the current version of the system requirements satisfy standard IEC 60601-1.



If components are used that do not correspond to the original parts, the performance, safety and EMC behaviour may be compromised.

## General safety information

### 1.7 Declaration on DEHP

The Thermia Pro devices do not contain bis(2-ethylhexyl) phthalates (DEHP).

### 1.8 Precautionary measures

Clean and disinfect all reusable components of the Thermia Pro as per the instructions (*chapter 7*) and replace all the disposable components before using the devices on another patient.

### 1.9 Target group (users)

These devices should only be used by doctors with experience in human medicine who have sufficient experience in the use of infusion solutions in medical applications.

## 2 Intended use

The Heating Trays from Möller Medical GmbH are designed to prevent hypothermic solutions. The Heating Trays are used in the field of body contouring and other medical applications.

### 2.1 Contraindications

- No contraindications are stated for the Thermia Pro devices.

### 2.2 Complications

- Hyperthermia
- Hypothermia
- Death

### 2.3 Essential performance features

The Thermia Pro devices have no essential performance characteristics.

### 2.4 Combination with other products

Only accessories that have been specified and approved by the device manufacturer should be used. Please contact the device manufacturer if you are unsure.

Product description

### 3 Product description

#### 3.1 Thermia Pro Console

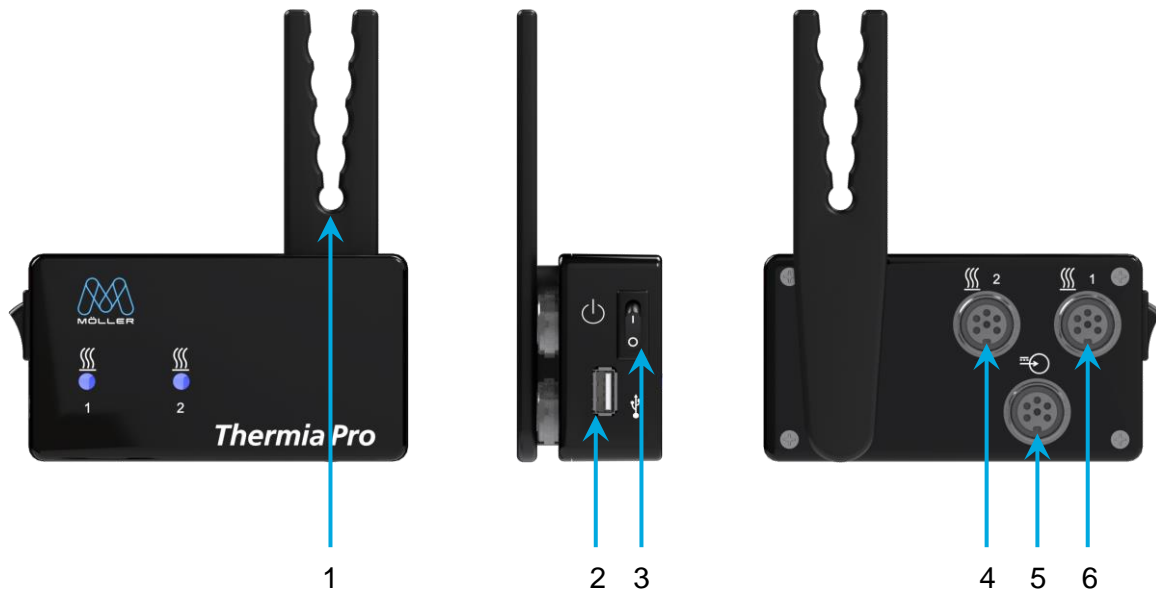

Figure 1:  
Thermia Pro Console

No.	Designation	No.	Designation
1	Bracket for cables and hoses	4	Connection socket for Heating Tray (2)
2	USB interface	5	Mains input socket
3	Standby switch	6	Connection socket for Heating Tray (1)

Table 2:  
Thermia Pro Console descriptions

**Product description**

**3.2 Thermia Pro Heating Trays mounted**

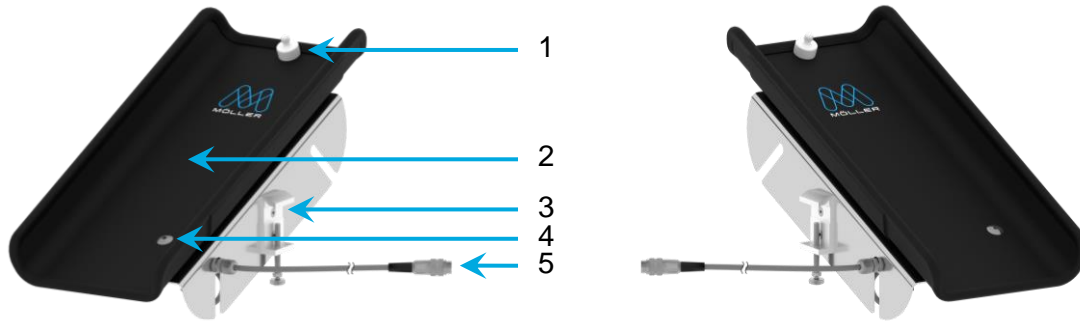

Figure 2:  
Thermia Pro Console mounted

No.	Description	No.	Description
1	Suspension system for saline bag	4	Temperature sensor
2	Heating Tray	5	Connecting cable to Thermia Pro Console
3	Clamping device		

Table 3:  
Thermia Pro mounted descriptions

**3.3 Thermia Pro Heating Trays stand-alone**

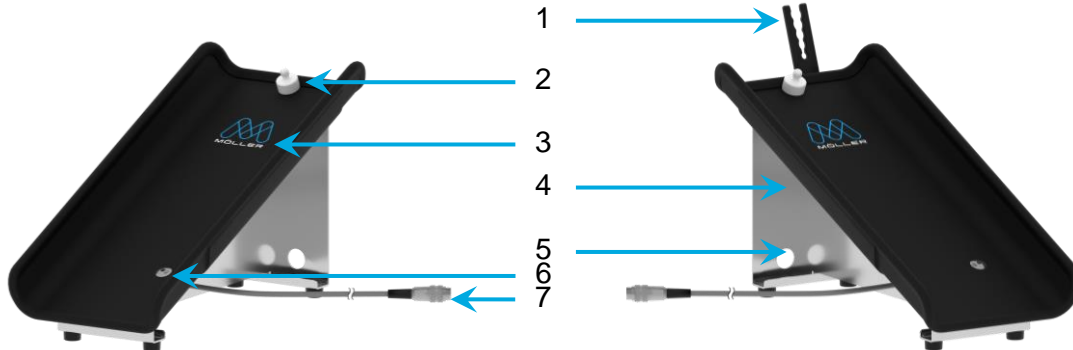

Figure 3:  
Thermia Pro Console stand-alone

No.	Description	No.	Description
1	Thermia Pro Console holder	5	Hole for connecting cable to Thermia Pro Console
2	Suspension system for saline bag	6	Temperature sensor
3	Heating Tray	7	Connecting cable to Thermia Pro Console
4	Supporting foot		

Table 4:  
Thermia Pro stand-alone descriptions

## Setup and commissioning

### 4 Setup and commissioning

#### 4.1 Transport and storage information

The following safety information must be observed when transporting the devices. This prevents damage to the devices and other property.



Make sure that the boxes are not damaged upon delivery to you. The forwarding agent must be notified immediately of any transport damage. Check all products for damage. Damaged products must not be used. Please contact your supplier immediately.

#### 4.2 Unpacking the devices and checking the delivered items



It is advisable not to dispose of the packaging and to use it again for any service required.

Only send the devices in their original packaging to prevent damage during transportation.

The Thermia Pro mounted is delivered in 2 packaging units. Make sure that no parts remain in the packaging when unpacking.

Scope of delivery:

Packaging unit	Contents
1	<ul style="list-style-type: none"> <li>• 1 Thermia Pro Console</li> <li>• 1 unlocking key with USB port blocker</li> <li>• 1 power supply</li> <li>• Right hose bracket (incl. mounting material)</li> <li>• Adapter</li> <li>• Instructions for use</li> </ul>
2	<ul style="list-style-type: none"> <li>• Thermia Pro Heating Trays mounted (2 Heating Trays: right, left)</li> <li>• Instructions for use</li> </ul>

Table 5:

*Thermia Pro mounted scope of delivery*

**Setup and commissioning**

The Thermia Pro stand-alone is delivered in 4 packaging units. Make sure that no parts remain in the packaging when unpacking.

Scope of delivery:

Packaging unit	Contents
1	<ul style="list-style-type: none"> <li>• 1 Thermia Pro Console</li> <li>• 1 unlocking key with USB port blocker</li> <li>• 1 power supply</li> <li>• Right hose bracket (including mounting material)</li> <li>• Adapter</li> <li>• Instructions for use</li> </ul>
2 + 3	<ul style="list-style-type: none"> <li>• 1 Thermia Pro Heating Tray stand-alone</li> <li>• Instructions for use</li> </ul>
4	<ul style="list-style-type: none"> <li>• 1 Thermia Pro Console holder</li> <li>• Screw set</li> </ul>

*Table 6:  
Thermia Pro stand-alone scope of delivery*

**4.3 Suitable operating environment**

The Thermia Pro devices are suitable for use in the following areas:

- Professional healthcare facilities with specific requirements  
 Clinics (rooms in A+E, hospital rooms, intensive care, operating theatres, except for in the proximity of active facilities of RF surgery devices or outside of the RF-shielded room for magnetic resonance imaging, first aid facilities).
- Home healthcare:  
 Home practices, lodgings (places of residence, nursing homes), hotels, guest houses and stationary vehicles, provided that the devices are not connected to the vehicle's DC power supply.

The Thermia Pro devices are not approved for use in aeroplanes and military areas. The appropriate EMC requirements for these environments have not been tested.

**4.4 Use with defibrillation and RF surgical devices**

See *chapter 4.3 "Suitable operating environment"*.



## Setup

### 5 Setup



- Prepare the Thermia Pro Console as well as the Thermia Pro Heating Trays before commissioning according to the instructions for use (*chapter 7*).
- Only use the power supply provided.
- Note the voltage values given on the device's rating plate.

#### 5.1 Setting up the Thermia Pro mounted

The Heating Trays mounted may only be used in connection with the Vacusat® power.



- The operation of the Thermia Pro mounted without the attachment to the Vacusat® power is prohibited.

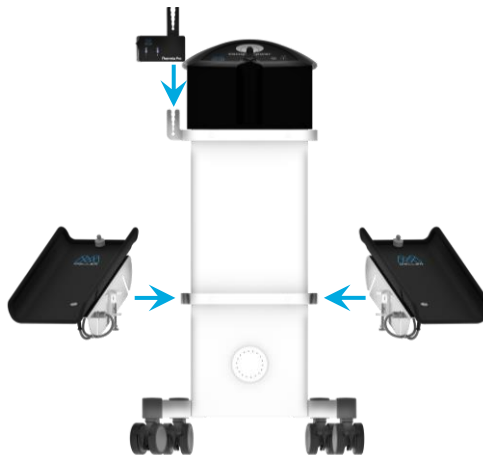

Figure 4:  
Overview drawing



Figure 5:  
Mount hose holder and plug in Console

## Setup

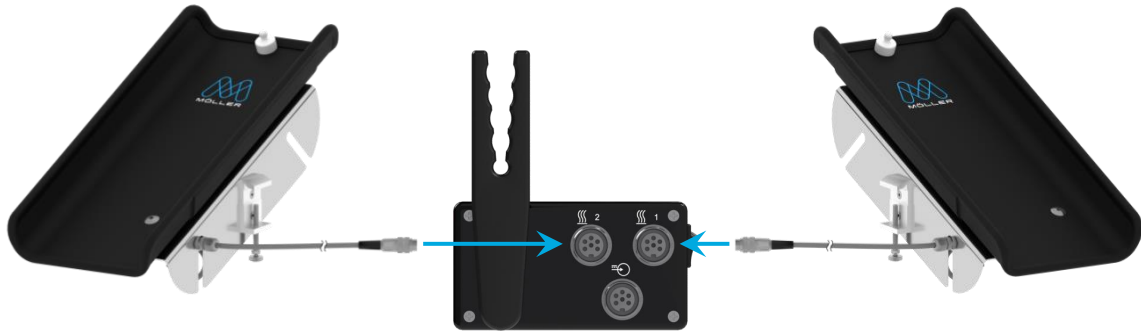

Figure 6:  
Connect the Thermia Pro mounted

### Replace the mains plug with country-specific sockets:

1. Press the button on the mains adapter.
2. Slide the mains adapter upwards.
3. Slide on the matching mains adapter.
4. Check the adapter for a tight fit.

### Setting up and connecting the Thermia Pro mounted:

1. Mount the hose holder with the opening facing upwards, on the left side (top view), on the Vacusat® power (Figure 5)
2. Hook the Thermia Pro Console into the hose holder (Figure 5).
3. Connect the supplied mains cable to the rear panel.
4. Plug the power supply unit into the socket.
5. Hang the heating trays on the clamping rail of the Vacusat® power and screw them tight by hand.
6. Align the guide rail of the connection socket (on the console) and the plug (on the connection cable of the Heating Tray).
7. Push the plug into the connection socket so that the guide rails interlock. There should be hardly any resistance (Figure 6).
8. As soon as greater resistance is felt, stop and check the alignment of the guide rails.
9. Tighten the lock nut by hand.
10. Gently moving the plug can make it easier to tighten.
11. Check that the Heating Trays are secure and tight.

## Setup

### 5.2 Setting up the Thermia Pro stand-alone

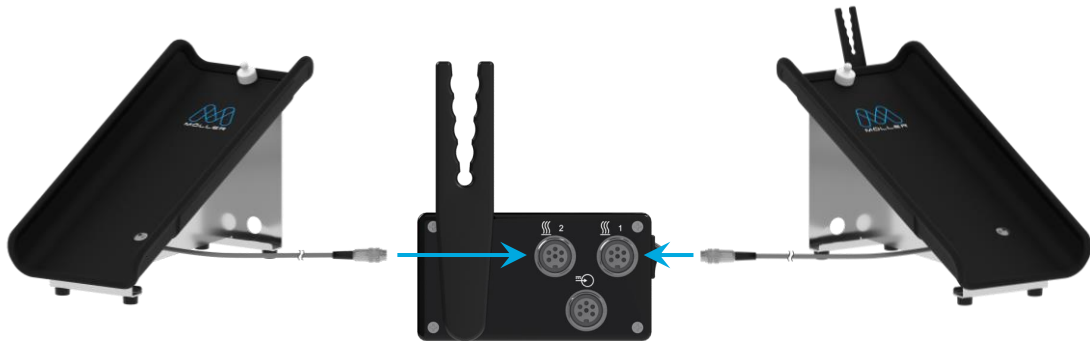

Figure 7:  
Connect the Thermia Pro stand-alone

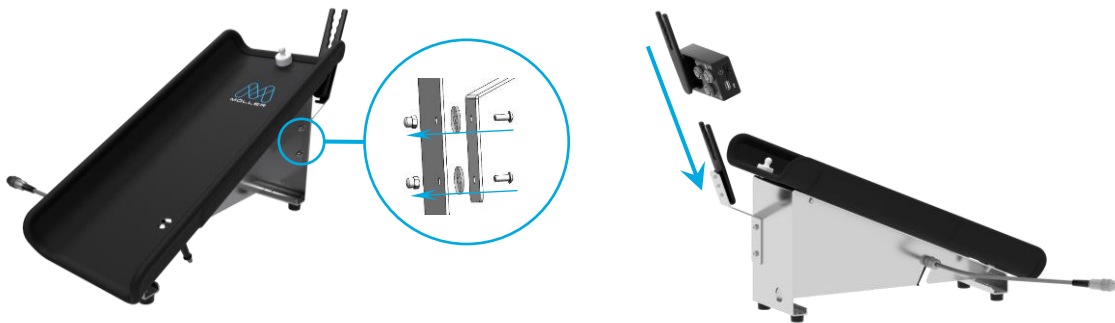

Figure 8:  
Mount console holder and plug in Console

1. Take the Heating Trays of the Thermia Pro stand-alone out of the packaging and place on a suitable firm surface.
2. Take the pre-mounted Thermia Pro holder with the respective screws out of the packaging and assemble these on any Thermia Pro Heating Tray stand-alone.
3. Remove the Thermia Pro Console out of the packaging and attach to the console holder of the Heating Tray. Connect the power supply to the back of the Console housing and insert the plug into the socket.
4. Plug the connection cables of the Heating Trays into a corresponding connection socket of the Thermia Pro Console.

## 6 Commissioning

Before commissioning, the Thermia Pro devices must be processed as per the hygiene guidelines (*chapter 7*).



If the Thermia Pro devices are subject to temperature and humidity fluctuations during transportation or other changes in location, the devices must be allowed to acclimatise for at least 2 hours before being put into service.

When setting up the Thermia Pro devices, make sure that:

- a sufficient distance from other devices is maintained. The devices require a space of at least 30 cm in height and width.
- the device can be turned off via the standby switch and disconnected from the mains by unplugging the mains cable.
- the devices are not operated in the direct proximity of or stacked with other devices as this may result in faulty operation. If operation as described above cannot be avoided, monitor the Thermia Pro devices and other devices to verify correct use.

### Always note:



- All handling of the device requires precise knowledge and compliance with these instructions for use.
- The devices may only be used by specialist staff.

When setting up the Thermia Pro Heating Trays mounted and Thermia Pro Heating Trays stand-alone, make sure of the following:



- Check the Heating Trays for mechanical damage before each use.
- The Heating Trays have a bag holder that ensures secure positioning of the saline bags. Make sure that the saline bags used have a compatible receptacle.
- When preheating, make sure that the liquid temperature is not above 37°C ( $\pm 1.5^\circ\text{C}$ ).
- The Heating Trays serve to maintain the temperature.
- The Heating Trays do not heat up the saline solution from a lower level.
- The Heating Tray temperature sensors record the temperature of the saline solution.
  - **For this, place the saline bag on the Heating Trays at least 5 minutes before use.** Make sure that the entire surface of the bag is positioned on the temperature sensor and that there are no other objects between the temperature sensor and the bag as this could otherwise impede temperature recording.

**Commissioning**

**Recorded outlet temperatures of the saline solution at the tube outlet (cannula)**

The following were checked:

Blue line	
REF 00004255	Thermia Pro stand-alone
REF 00003977	Liposat® Pro
REF 00002251	TLA Tubing Liposat® Pro/power

Table 7:  
Application with the Liposat® Pro

Orange line	
REF 00004255	Thermia Pro stand-alone
REF 00003974	Liposat® Pro plus
REF 00003997	TLA Tubing Liposat® Pro plus

Table 8:  
Application with the Liposat® Pro plus

The tests were performed at room temperature, 24°C.

Delivery rate [ml/min]	Liposat® Pro [°C]
50	31.1
100	33.1
200	34.3
300	34.6

Table 9:  
Data of the Liposat® Pro

Delivery rate [ml/min]	Liposat® Pro plus [°C]
50	30.2
100	32.4
300	34
650	34.6
1000	35.3

Table 10:  
Data of the Liposat® Pro plus

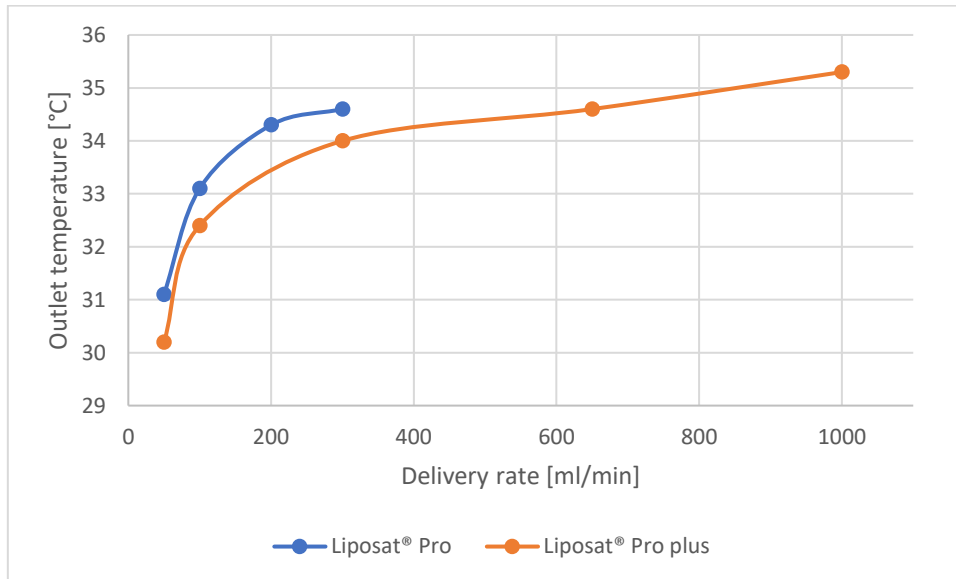

Figure 9:  
Graphical representation of the data

## Commissioning

Either one or two Heating Trays can be connected to the Thermia Pro Console. The application is the responsibility of the user. The Heating Trays are activated using the standby switch on the Console. The standby switch switches all connected Heating Trays on or off simultaneously.



Figure 10:  
Thermia Pro Console LED symbols

The Heating Tray function is displayed via two LEDs on the front. The 1 and 2 stand for the respective input sockets on the back, which are also marked with 1 and 2.

A **white** LED indicates that the Heating Tray is ready for use and there are no errors.

A **yellow** LED indicates that this Heating Tray detects a temperature in excess of 42°C ( $\pm 1.5^\circ\text{C}$ ).

An **unlit** LED indicates that this Heating Tray is not recognised.

To clear the faults, follow the instructions in Chapter 8.

## Cleaning and care

### 7 Cleaning and care



- No moisture must be allowed to enter the device.
- Before cleaning and disinfecting the device surfaces, disconnect the mains plug.
- Use a lint-free, soft cloth for cleaning and disinfecting.
- Wipe the devices to clean and disinfect them. Immersing or spraying the devices may lead to hazards and destroy the devices.
- Sterilisation processes such as autoclaving and ethylene oxide sterilisation render the devices unusable.

Clean using a cloth dampened with mild soap solution or 70% isopropanol solution.

After cleaning, disinfect the surfaces of the Thermia Pro devices with a pH neutral, approved detergent-alcohol based disinfectant with up to 70% alcohol (e.g. Propan-1-ol, recommended disinfectant: Meliseptol®). During disinfection, follow the instructions of the disinfectant manufacturer.

Ensure that the cleaning and disinfecting agents have fully evaporated before using the devices.

#### **Visual inspection:**

The sockets of all connections and plugs of the cables to be connected must be free of all types of dirt.

## 8 Help in the event of a fault



The Thermia Pro devices must not be opened by the user!

This chapter describes certain problems that may occur in connection with the devices. The Thermia Pro Console must always be turned off when connecting and disconnecting plug connections.

If an error cannot be remedied in this manner, contact the Möller Medical GmbH service centre ([service@moeller-medical.com](mailto:service@moeller-medical.com)) or a partner authorised by the manufacturer.

Problem	Solution
No function.	The device is not switched on or not connected to the power supply properly. Check the power supply, possibly switch on multiple sockets, check supply lines and building circuit breaker.
Moisture has entered into the plug.	Pull the plug off the device and out of the socket. Allow the plug to dry.
One LED remains dark.	The corresponding Heating Tray was not detected. Check the plug connection.
One LED lights up yellow.	The corresponding temperature sensor has recorded a temperature in excess of 42°C (±1.5°C). Stop the application and allow the infiltration solution to cool down.
Should these measures not prove successful, the device is to be checked by the Möller Medical GmbH service team.	



## 9 Service



Before disposing of or returning the Thermia Pro devices, a suitable disinfection procedure must be carried out to rule out the risk of possible infection. Consumable materials should be disposed of in accordance with hygiene guidelines.



**Service note:**

**Never open the device when it is connected to the mains power supply. Even when not connected to the mains, internal parts may still be live.**

**Möller Medical GmbH service centre:**

**Möller Medical GmbH**

Wasserkuppenstrasse 29-31

36043 Fulda, Germany

Tel. +49 (0) 661 / 94 19 5 – 0

Fax +49 (0) 661 / 94 19 5 – 850

[www.moeller-medical.com](http://www.moeller-medical.com)

[info@moeller-medical.com](mailto:info@moeller-medical.com)



**MÖLLER**

**Service**

E-mail: [service@moeller-medical.com](mailto:service@moeller-medical.com)

## 9.1 Software update



- Observe the order of the update. Deviations can result in the software update being cancelled or unsuccessful.
- Note that the USB port blocker key may break if used incorrectly.

### Explanation of symbols used



Device switched on (Standby Off)



Standby switch

Device switched off (Standby On)

Table 11:  
Explanation of symbols used

The software can be updated via the USB service interface on the back of the devices. To update, proceed as follows:

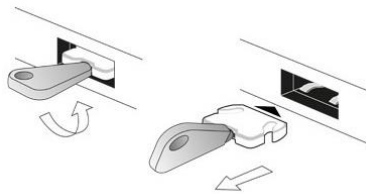

Figure 11:  
Removing the USB port blocker

#### Preparation

1. Use an empty USB stick without subdirectories.
2. Copy the software to the USB stick.
  - a. The software is provided by the service centre.
3. Set the **Standby Switch** on the back of the device to **Standby On**.

#### Update device

4. Pull out the mains plug.
5. Insert the unlocking key into the hole of the USB port blocker.
6. Carefully turn the unlocking key to the left.
  - ➔ As soon as slight resistance is felt, carefully pull the unlocking key to remove the USB port blocker.
7. Insert the prepared USB stick into the USB service interface.
8. Plug in the mains plug.
9. Watch the LEDs, the update is done automatically.
10. If the LEDs alternately flash white, the update is in progress.
11. If both LEDs flash green at the same time, the update was successful.
12. If both LEDs flash yellow, the update was not successful.
  - ➔ See *chapter 9.1.1*.
13. Pull out the mains plug.

## Service

14. Remove the USB stick.
15. Plug the USB port blocker into the USB service interface.
16. Plug in the mains plug.
  - ➔ The device is now updated.

### 9.1.1 “First aid”

#### If the update is unsuccessful

- ➔ The LEDs flash yellow.
- ➔ The old software is kept on the device.
- ➔ Do the above steps again.

If the following steps do not solve the issue, contact the service centre.

#### Possible sources of error and how to eliminate them

- Was the firmware file copied correctly onto the USB stick?
  - ➔ If necessary, unzip the firmware file and copy again onto the USB stick.
- Was the voltage disconnected briefly whilst the firmware was being installed?
  - ➔ Install the firmware again as described in *chapter 9.1*.
- Was the USB stick detected correctly?
  - ➔ Copy the firmware onto another USB stick and try the update again.

## 10 Disposal

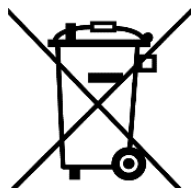

These devices include materials that must be disposed of in an environmentally friendly manner. The European Directive 2012/19/EU on waste electrical and electronic equipment (WEEE2) applies to these devices. They thus bear the symbol with a crossed out bin on the rating plate.

Process and return devices that are no longer used to Möller Medical GmbH. This ensures that the devices are disposed of in compliance with the national requirements of the WEEE Directive.

## Annex

# 11 Annex

## 11.1 Technical data

### Article number

Thermia Pro mounted	REF 00004253
Thermia Pro stand-alone	REF 00004255
Thermia Pro Console	REF 00004249
Thermia Pro Heating Trays mounted (set of 2)	REF 00002542
Thermia Pro Heating Trays stand-alone (set of 2)	REF 00002286

### Dimensions

(Height x width x depth)

Thermia Pro Console	43 mm x 135 mm x 118 mm
Thermia Pro Heating Trays mounted	132 mm x 213 mm x 463 mm
Thermia Pro Heating Trays stand-alone	259 mm x 204 mm x 432 mm

### Weight

Thermia Pro Console (+ mains adapter)	Approx. 0.4 kg
Thermia Pro Heating Trays mounted	Approx. 1.9 kg per Heating Tray mounted
Thermia Pro Heating Trays stand-alone	Approx. 2.7 kg per Heating Tray stand-alone

### Electrical connection of the external power supply of the Thermia Pro Console

Voltage	100 – 240 V AC
Frequency	50 / 60 Hz
Current consumption	1.5 – 0.8 A

### Safety

Protective class	II
------------------	----

### Electrical connection of the Thermia Pro Console

Voltage	24 VDC (DC voltage)
Current consumption	Max. 2.5 A

### Safety

Protective class	II
------------------	----

## 11.2 General data

### Transport and storage information

Temperature	-10°C to +50°C
Air humidity	< 90% relative humidity

### Dimensions with packaging:

(Height x width x depth)

Thermia Pro Console	110 mm x 300 mm x 210 mm
Thermia Pro Heating Trays mounted	300 mm x 300 mm x 540 mm
Thermia Pro Heating Trays stand-alone	300 mm x 300 mm x 540 mm

Store the packaged devices in a dry place.

A stack of packed devices may consist of max. 3 packages.

### Operating conditions

Temperature	+10°C to +30°C
Air humidity	30 to 75% relative humidity
Atmospheric pressure	70.1 kPa – 101.3 kPa (3000-0 m MSL)
Minimum operating lifespan	8 years

## Electromagnetic compatibility

# 12 Electromagnetic compatibility

## 12.1 Electromagnetic emissions

The Thermia Pro devices are intended for use in the electromagnetic environment specified. The customer and/or operator of the Thermia Pro devices must ensure that the device is used in the electromagnetic environment described below.

Measurement of electromagnetic interference	Compliance	Electromagnetic environment guidelines
RF electromagnetic interference acc. to CISPR 11	Group 1	To satisfy their intended function, the Thermia Pro devices must emit electromagnetic energy. Electronic devices in the vicinity could be influenced.
RF electromagnetic interference acc. to CISPR 11	Class B	For areas of application, see <i>chapter 4.3</i> "Suitable operating environment"
Harmonic emissions acc. to IEC 61000-3-2	Class A	
Voltage fluctuations/flicker acc. to IEC 61000-3-3	Complies	

## Electromagnetic compatibility

### 12.2 Electromagnetic immunity

Immunity test	IEC 60601 - testing level	Compliance level	Electromagnetic environment / guidelines
Discharge of static electricity (ESD) IEC 61000-4-2	±8 kV contact discharge ±15 kV air discharge	±8 kV contact discharge ±15 kV air discharge	Floors should be wood, concrete or ceramic tile. If floors are covered with synthetic material, the relative humidity should be at least 30%.
Electrical fast transient/burst acc. to IEC 61000-4-4	±2 kV for power supply lines ±1 kV for input/output lines	±2 kV for power supply lines ±1 kV for input/output lines	The quality of the supply voltage should be comparable to that for a typical shop or hospital environment.
Impulse voltage (surges) IEC 61000-4-5	±1 kV differential mode ±2 kV common mode	±1 kV differential mode ±2 kV common mode	The quality of the supply voltage should be comparable to that for a typical shop or hospital environment.
Voltage dips, short interruptions and voltage variations on power supply input lines IEC 61000-4-11	< 5% $U_T$ (> 95% dips of $U_T$ ) for 0.5 cycle  40% $U_T$ (60% dips of $U_T$ ) for 5 cycles  70% $U_T$ (30% dips of $U_T$ ) for 25 cycles  < 5% $U_T$ (> 95% dips of $U_T$ ) for 5 seconds	< 5% $U_T$ (> 95% dips of $U_T$ ) for 0.5 cycle  40% $U_T$ (60% dips of $U_T$ ) for 5 cycles  70% $U_T$ (30% dips of $U_T$ ) for 25 cycles  < 5% $U_T$ (> 95% dips of $U_T$ ) for 5 seconds	The quality of the supply voltage should be comparable to that for a typical shop or hospital environment. If the user of the device requires continued operation during power mains interruptions, it is recommended that the device be powered from an uninterruptible power supply or battery.
Power frequency (50/60 Hz) magnetic field acc. to IEC 61000-4-8	30 A/m	30 A/m	Magnetic fields of the supply frequency should conform with the typical values found in shops or hospital environments.



## Electromagnetic compatibility

Immunity test	IEC 60601 - testing level	Compliance level	Electromagnetic environment / guidelines
Note: $U_T$ is the AC mains voltage prior to application of the test level.			

The Thermia Pro devices satisfy all test levels in accordance with IEC60601-1-2 Edition 4 (table 4 to 9).



Portable RF communications equipment (radio devices) (including their accessories such as antenna cables and external antennas) should not be used closer than 30 cm (or 12 inches) from the parts and cables of the Thermia Pro devices indicated by the manufacturer. Non-observance may result in a reduction of the device's performance.



Operation of the Thermia Pro devices with additional accessories such as transducers or cables, which are not defined for the intended use with the device, may result in increased electromagnetic emissions, reduced immunity to interference or faulty operation.

The requirements for use in aviation, transportation and military fields have not been taken into account as they have not been tested.

**Electromagnetic compatibility**

Electromagnetic immunity/standard	IEC 60601 - testing level	Compliance level	Electromagnetic environment / guidelines
Conducted RF disturbances acc. to IEC 61000-4-6	<p>3 V<sub>eff</sub> 150 kHz to 80 MHz</p> <p>6 V<sub>eff</sub> in ISM and amateur radio frequency bands between 150 kHz and 80 MHz</p>	<p>3 V<sub>eff</sub></p> <p>6 V<sub>eff</sub></p>	<p>Portable and mobile RF communications equipment should be used no closer to any part of the Thermia Pro devices, including cables, than the recommended separation distance calculated from the equation applicable to the frequency of the transmitter.</p> <p><b>Recommended separation distance:</b>  <math>d = 1,2\sqrt{P}</math> for 80 MHz to 800 MHz  <math>d = 2,3\sqrt{P}</math> for 800 MHz to 2.5 GHz</p> <p>Where P is the nominal transmitter power in watts (W) according to the transmitter manufacturer and d is the recommended separation distance in metres (m). Field strengths from fixed RF transmitters, as determined by an electromagnetic site survey <sup>a)</sup> should be less than the compliance level in each frequency range <sup>b)</sup>. Interference may occur in the vicinity of the devices marked with the following symbol: </p>
Radiated RF disturbance value acc. to IEC 61000-4-3	<p>3 V/m 80 MHz to 2.7 GHz</p> <p>Table 9 of IEC 60601-1-2 Ed. 4</p>	<p>3 V/m 80 MHz to 2.7 GHz</p> <p>Table 9 of IEC 60601-1-2 Ed. 4</p>	
<p>Notes:</p> <p>NOTE 1: At 80 MHz and 800 MHz, the higher frequency range applies.</p> <p>NOTE 2: These guidelines may not apply in all situations. Electromagnetic propagation is affected by absorption and reflection by structures, objects and people.</p>			
<p><sup>a)</sup> Field strengths from fixed transmitters, such as base stations for radio (cellular/cordless) telephones and land mobile radios, amateur radio, AM and FM radio broadcast and TV broadcast cannot be predicted theoretically with accuracy. To assess the electromagnetic environment due to fixed transmitters, an electromagnetic site survey should be considered. If the measured field strength at the site at which the Thermia Pro devices are used exceeds the compliance levels above, the devices should be monitored to ensure that they are working properly. If the Thermia Pro devices are not performing as expected, additional measures may be necessary, such as changing the direction in which they are facing or moving them to another area.</p> <p><sup>b)</sup> Over the frequency range 150 kHz to 80 MHz, field strengths should be less than 3 V/m.</p>			

**12.3 Recommended separation distances**

See chapter 12.2 “Electromagnetic immunity”.

## Accessories

## 13 Accessories

## Spare parts

Thermia Pro Heating Trays mounted

(Pack of 2 in a set)

Catalogue no.: 00002542



Thermia Pro Heating Trays stand-alone

(Pack of 2 in a set)

Catalogue no.: 00002286



Thermia Pro Console holder

(incl. mounting material)

Catalogue no.: 92018061



Right hose bracket

(incl. mounting material)

Catalogue no.: 93007658



Unlocking key with USB port blocker

Catalogue no.: 93006998



Revision status: 2023-05 V01  
Software version: 104.00.01



Instructions for use  
catalogue number  
(REF) 93007595



Möller Medical GmbH  
Wasserkuppenstrasse 29-31  
36043 Fulda, Germany

Tel. +49 (0) 661 / 94 19 5 – 0  
Fax +49 (0) 661 / 94 19 5 – 850  
[www.moeller-medical.com](http://www.moeller-medical.com)  
[info@moeller-medical.com](mailto:info@moeller-medical.com)

